

A
B
C

SECTION **GW**

GLASS & WINDOW SYSTEM

CONTENTS

PRECAUTION	2	Removal and Installation	11	F
PRECAUTIONS	2	FRONT DOOR GLASS	14	
Precaution for Supplemental Restraint System (SRS) "AIR BAG" and "SEAT BELT PRE-TENSIONER"	2	Exploded View	14	G
Handling for Adhesive and Primer	2	Removal and Installation	14	
Procedure without Cowl Top Cover	2	FRONT REGULATOR	16	
Precaution for Work	2	Exploded View	16	H
PREPARATION	4	Removal and Installation	16	
PREPARATION	4	FRONT POWER WINDOW MOTOR	19	
Special Service Tool	4	Removal and Installation	19	I
Commercial Service Tool	4	REAR DOOR GLASS	20	
SYMPTOM DIAGNOSIS	5	Exploded View	20	J
SQUEAK AND RATTLE TROUBLE DIAGNOSES	5	Removal and Installation	20	
Work Flow	5	REAR REGULATOR	22	
Generic Squeak and Rattle Troubleshooting	6	Exploded View	22	GW
Diagnostic Worksheet	9	Removal and Installation	22	
REMOVAL AND INSTALLATION	11	REAR POWER WINDOW MOTOR	25	
WINDSHIELD GLASS	11	Removal and Installation	25	L
Exploded View	11	REAR WINDOW GLASS	26	
		Exploded View	26	M
		Removal and Installation	27	

PRECAUTIONS

< PRECAUTION >

PRECAUTION

PRECAUTIONS

Precaution for Supplemental Restraint System (SRS) "AIR BAG" and "SEAT BELT PRE-TENSIONER"

INFOID:000000012248938

The Supplemental Restraint System such as "AIR BAG" and "SEAT BELT PRE-TENSIONER", used along with a front seat belt, helps to reduce the risk or severity of injury to the driver and front passenger for certain types of collision. Information necessary to service the system safely is included in the SR and SB section of this Service Manual.

WARNING:

- To avoid rendering the SRS inoperative, which could increase the risk of personal injury or death in the event of a collision which would result in air bag inflation, all maintenance must be performed by an authorized NISSAN/INFINITI dealer.
- Improper maintenance, including incorrect removal and installation of the SRS, can lead to personal injury caused by unintentional activation of the system. For removal of Spiral Cable and Air Bag Module, see the SR section.
- Do not use electrical test equipment on any circuit related to the SRS unless instructed to in this Service Manual. SRS wiring harnesses can be identified by yellow and/or orange harnesses or harness connectors.

PRECAUTIONS WHEN USING POWER TOOLS (AIR OR ELECTRIC) AND HAMMERS

WARNING:

- When working near the Airbag Diagnosis Sensor Unit or other Airbag System sensors with the Ignition ON or engine running, DO NOT use air or electric power tools or strike near the sensor(s) with a hammer. Heavy vibration could activate the sensor(s) and deploy the air bag(s), possibly causing serious injury.
- When using air or electric power tools or hammers, always switch the Ignition OFF, disconnect the battery and wait at least three minutes before performing any service.

Handling for Adhesive and Primer

INFOID:000000012248927

- Do not use an adhesive which is past its usable date. Shelf life of this product is limited to six months after the date of manufacture. Carefully adhere to the expiration or manufacture date printed on the box.
- Keep primers and adhesive in a cool, dry place. Ideally, they should be stored in a refrigerator.
- Open the seal of the primer and adhesive just before application. Discard the remainder.
- Before application, be sure to shake the primer container to stir the contents. If any floating material is found, do not use it.
- If any primer or adhesive contacts the skin, wipe it off with gasoline or equivalent and wash the skin with soap.
- When using primer and adhesive, always observe the precautions in the instruction manual.

Procedure without Cowl Top Cover

INFOID:000000012248928

When performing the procedure after removing cowl top cover, cover the lower end of windshield with urethane, etc. to prevent damage to the windshield.

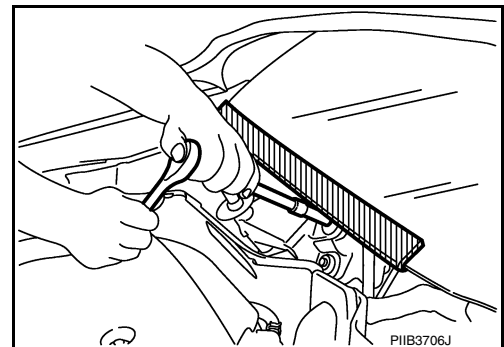

Precaution for Work

INFOID:000000012248929

- When removing or disassembling each component, be careful not to damage or deform it. If a component may be subject to interference, be sure to protect it with a shop cloth.

PRECAUTIONS

< PRECAUTION >

- When removing (disengaging) components with a screwdriver or similar tool, be sure to wrap the component with a shop cloth or vinyl tape to protect it. A
- Protect the removed parts with a shop cloth and prevent them from being dropped.
- Replace a deformed or damaged clip.
- If a part is specified as a non-reusable part, always replace it with a new one. B
- Be sure to tighten bolts and nuts securely to the specified torque.
- After installation is complete, be sure to check that each part works properly.
- Follow the steps below to clean components:
 - Water soluble dirt: C
 - Dip a soft cloth into lukewarm water, wring the water out of the cloth and wipe the dirty area.
 - Then rub with a soft, dry cloth.
 - Oily dirt: D
 - Dip a soft cloth into lukewarm water with mild detergent (concentration: within 2 to 3%) and wipe the dirty area.
 - Then dip a cloth into fresh water, wring the water out of the cloth and wipe the detergent off. E
 - Then rub with a soft, dry cloth.
 - Do not use organic solvent such as thinner, benzene, alcohol or gasoline.
 - For genuine leather seats, use a genuine leather seat cleaner. F

F

G

H

I

J

GW

L

M

N

O

P

PREPARATION

< PREPARATION >

PREPARATION

PREPARATION

Special Service Tool

INFOID:000000012248930

The actual shape of the tools may differ from those illustrated here.

Tool number (TechMate No.) Tool name	Description
— (J-39570) Chassis Ear	Locating the noise
— (J-50397) NISSAN Squeak and Rattle Kit	Repairing the cause of noise
— (J-46534) Trim Tool Set	Removing trim components

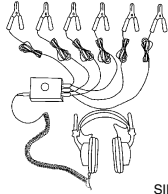

SIIA0993E



ALJIA1232ZZ

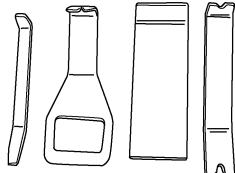

AWJIA0483ZZ

Commercial Service Tool

INFOID:000000012248931

(TechMate No.) Tool name	Description
(J-39565) Engine Ear	Locating the noise
(—) Suction Lifter	Holding door glass

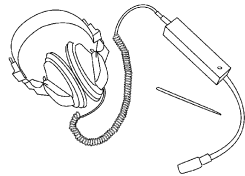

SIIA0995E

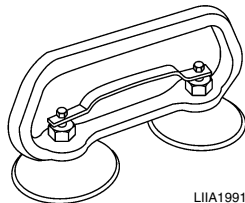

LIIA1991E

SQUEAK AND RATTLE TROUBLE DIAGNOSES

< SYMPTOM DIAGNOSIS >

SYMPTOM DIAGNOSIS

SQUEAK AND RATTLE TROUBLE DIAGNOSES

Work Flow

INFOID:0000000012248935

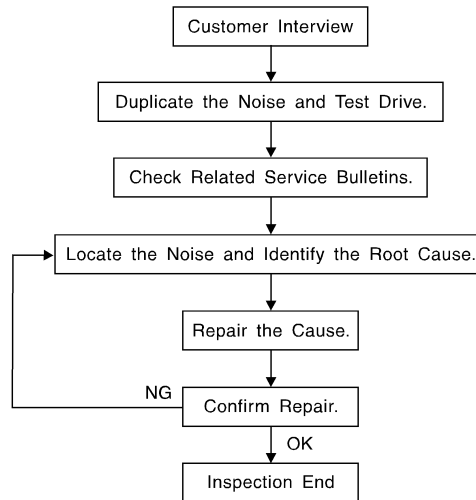

SBT842

CUSTOMER INTERVIEW

Interview the customer if possible, to determine the conditions that exist when the noise occurs. Use the Diagnostic Worksheet during the interview to document the facts and conditions when the noise occurs and any customer's comments; refer to [GW-9, "Diagnostic Worksheet"](#). This information is necessary to duplicate the conditions that exist when the noise occurs.

- The customer may not be able to provide a detailed description or the location of the noise. Attempt to obtain all the facts and conditions that exist when the noise occurs (or does not occur).
- If there is more than one noise in the vehicle, be sure to diagnose and repair the noise that the customer is concerned about. This can be accomplished by test driving the vehicle with the customer.
- After identifying the type of noise, isolate the noise in terms of its characteristics. The noise characteristics are provided so the customer, service adviser and technician are all speaking the same language when defining the noise.
- Squeak —(Like tennis shoes on a clean floor)
Squeak characteristics include the light contact/fast movement/brought on by road conditions/hard surfaces = higher pitch noise/softer surfaces = lower pitch noises/edge to surface = chirping.
- Creak—(Like walking on an old wooden floor)
Creak characteristics include firm contact/slow movement/twisting with a rotational movement/pitch dependent on materials/often brought on by activity.
- Rattle—(Like shaking a baby rattle)
Rattle characteristics include the fast repeated contact/vibration or similar movement/loose parts/missing clip or fastener/incorrect clearance.
- Knock —(Like a knock on a door)
Knock characteristics include hollow sounding/sometimes repeating/often brought on by driver action.
- Tick—(Like a clock second hand)
Tick characteristics include gentle contacting of light materials/loose components/can be caused by driver action or road conditions.
- Thump—(Heavy, muffled knock noise)
Thump characteristics include softer knock/dead sound often brought on by activity.
- Buzz—(Like a bumble bee)
Buzz characteristics include high frequency rattle/firm contact.
- Often the degree of acceptable noise level will vary depending upon the person. A noise that you may judge as acceptable may be very irritating to the customer.
- Weather conditions, especially humidity and temperature, may have a great effect on noise level.

DUPLICATE THE NOISE AND TEST DRIVE

SQUEAK AND RATTLE TROUBLE DIAGNOSES

< SYMPTOM DIAGNOSIS >

If possible, drive the vehicle with the customer until the noise is duplicated. Note any additional information on the Diagnostic Worksheet regarding the conditions or location of the noise. This information can be used to duplicate the same conditions when you confirm the repair.

If the noise can be duplicated easily during the test drive, to help identify the source of the noise, try to duplicate the noise with the vehicle stopped by doing one or all of the following:

- 1) Close a door.
 - 2) Tap or push/pull around the area where the noise appears to be coming from.
 - 3) Rev the engine.
 - 4) Use a floor jack to recreate vehicle "twist".
 - 5) At idle, apply engine load (electrical load, half-clutch on M/T model, drive position on CVT and A/T models).
 - 6) Raise the vehicle on a hoist and hit a tire with a rubber hammer.
- Drive the vehicle and attempt to duplicate the conditions the customer states exist when the noise occurs.
 - If it is difficult to duplicate the noise, drive the vehicle slowly on an undulating or rough road to stress the vehicle body.

CHECK RELATED SERVICE BULLETINS

After verifying the customer concern or symptom, check ASIST for Technical Service Bulletins (TSBs) related to that concern or symptom.

If a TSB relates to the symptom, follow the procedure to repair the noise.

LOCATE THE NOISE AND IDENTIFY THE ROOT CAUSE

1. Narrow down the noise to a general area. To help pinpoint the source of the noise, use a listening tool (Chassis Ear: J-39570, Engine Ear: J-39565 and mechanic's stethoscope).
2. Narrow down the noise to a more specific area and identify the cause of the noise by:
 - removing the components in the area that you suspect the noise is coming from.
Do not use too much force when removing clips and fasteners, otherwise clips and fasteners can be broken or lost during the repair, resulting in the creation of new noise.
 - tapping or pushing/pulling the component that you suspect is causing the noise.
Do not tap or push/pull the component with excessive force, otherwise the noise will be eliminated only temporarily.
 - feeling for a vibration with your hand by touching the component(s) that you suspect is (are) causing the noise.
 - placing a piece of paper between components that you suspect are causing the noise.
 - looking for loose components and contact marks.
Refer to [GW-6, "Generic Squeak and Rattle Troubleshooting"](#).

REPAIR THE CAUSE

- If the cause is a loose component, tighten the component securely.
- If the cause is insufficient clearance between components:
 - separate components by repositioning or loosening and retightening the component, if possible.
 - insulate components with a suitable insulator such as urethane pads, foam blocks, felt cloth tape or urethane tape. A NISSAN Squeak and Rattle Kit (J-50397) is available through your authorized NISSAN Parts Department.

CAUTION:

Do not use excessive force as many components are constructed of plastic and may be damaged.

NOTE:

- Always check with the Parts Department for the latest parts information.
- The materials contained in the NISSAN Squeak and Rattle Kit (J-50397) are listed on the inside cover of the kit; and can each be ordered separately as needed.
- The following materials not found in the kit can also be used to repair squeaks and rattles.
 - SILICONE GREASE: Use instead of UHMW tape that will be visible or does not fit. The silicone grease will only last a few months.
 - SILICONE SPRAY: Use when grease cannot be applied.
 - DUCT TAPE: Use to eliminate movement.

CONFIRM THE REPAIR

Confirm that the cause of a noise is repaired by test driving the vehicle. Operate the vehicle under the same conditions as when the noise originally occurred. Refer to the notes on the Diagnostic Worksheet.

Generic Squeak and Rattle Troubleshooting

INFOID:000000012248936

Refer to Table of Contents for specific component removal and installation information.

SQUEAK AND RATTLE TROUBLE DIAGNOSES

< SYMPTOM DIAGNOSIS >

INSTRUMENT PANEL

Most incidents are caused by contact and movement between:

1. Cluster lid A and the instrument panel
2. Acrylic lens and combination meter housing
3. Instrument panel to front pillar finisher
4. Instrument panel to windshield
5. Instrument panel pins
6. Wiring harnesses behind the combination meter
7. A/C defroster duct and duct joint

These incidents can usually be located by tapping or moving the components to duplicate the noise or by pressing on the components while driving to stop the noise. Most of these incidents can be repaired by applying felt cloth tape or silicone spray (in hard to reach areas). Urethane pads can be used to insulate wiring harness.

CAUTION:

Do not use silicone spray to isolate a squeak or rattle. If you saturate the area with silicone, you will not be able to recheck the repair.

CENTER CONSOLE

Components to pay attention to include:

1. Shift selector assembly cover to finisher
2. A/C control unit and cluster lid C
3. Wiring harnesses behind audio and A/C control unit

The instrument panel repair and isolation procedures also apply to the center console.

DOORS

Pay attention to the:

1. Finisher and inner panel making a slapping noise
2. Inside handle escutcheon to door finisher
3. Wiring harnesses tapping
4. Door striker out of alignment causing a popping noise on starts and stops

Tapping or moving the components or pressing on them while driving to duplicate the conditions can isolate many of these incidents. You can usually insulate the areas with felt cloth tape or insulator foam blocks from the NISSAN Squeak and Rattle Kit (J-50397) to repair the noise.

TRUNK

Trunk noises are often caused by a loose jack or loose items put into the trunk by the owner.

In addition look for:

1. Trunk lid bumpers out of adjustment
2. Trunk lid striker out of adjustment
3. The trunk lid torsion bars knocking together
4. A loose license plate or bracket

Most of these incidents can be repaired by adjusting, securing or insulating the item(s) or component(s) causing the noise.

SUNROOF/HEADLINING

Noises in the sunroof/headlining area can often be traced to one of the following:

1. Sunroof lid, rail, linkage or seals making a rattle or light knocking noise
2. Sun visor shaft shaking in the holder
3. Front or rear windshield touching headliner and squeaking

Again, pressing on the components to stop the noise while duplicating the conditions can isolate most of these incidents. Repairs usually consist of insulating with felt cloth tape.

OVERHEAD CONSOLE (FRONT AND REAR)

Overhead console noises are often caused by the console panel clips not being engaged correctly. Most of these incidents are repaired by pushing up on the console at the clip locations until the clips engage.

In addition look for:

A

B

C

D

E

F

G

H

I

J

GW

L

M

N

O

P

SQUEAK AND RATTLE TROUBLE DIAGNOSES

< SYMPTOM DIAGNOSIS >

1. Loose harness or harness connectors.
2. Front console map/reading lamp lens loose.
3. Loose screws at console attachment points.

SEATS

When isolating seat noise it's important to note the position the seat is in and the load placed on the seat when the noise is present. These conditions should be duplicated when verifying and isolating the cause of the noise.

Cause of seat noise include:

1. Headrest rods and holder
2. A squeak between the seat pad cushion and frame
3. The rear seatback lock and bracket

These noises can be isolated by moving or pressing on the suspected components while duplicating the conditions under which the noise occurs. Most of these incidents can be repaired by repositioning the component or applying urethane tape to the contact area.

UNDERHOOD

Some interior noise may be caused by components under the hood or on the engine wall. The noise is then transmitted into the passenger compartment.

Causes of transmitted underhood noise include:

1. Any component installed to the engine wall
2. Components that pass through the engine wall
3. Engine wall mounts and connectors
4. Loose radiator installation pins
5. Hood bumpers out of adjustment
6. Hood striker out of adjustment

These noises can be difficult to isolate since they cannot be reached from the interior of the vehicle. The best method is to secure, move or insulate one component at a time and test drive the vehicle. Also, engine rpm or load can be changed to isolate the noise. Repairs can usually be made by moving, adjusting, securing, or insulating the component causing the noise.

SQUEAK AND RATTLE TROUBLE DIAGNOSES

< SYMPTOM DIAGNOSIS >

Diagnostic Worksheet

INFOID:000000012248937

Dear Customer:

We are concerned about your satisfaction with your vehicle. Repairing a squeak or rattle sometimes can be very difficult. To help us fix your vehicle right the first time, please take a moment to note the area of the vehicle where the squeak or rattle occurs and under what conditions. You may be asked to take a test drive with a service advisor or technician to ensure we confirm the noise you are hearing.

SQUEAK & RATTLE DIAGNOSTIC WORKSHEET

I. WHERE DOES THE NOISE COME FROM? (circle the area of the vehicle)

The illustrations are for reference only, and may not reflect the actual configuration of your vehicle.

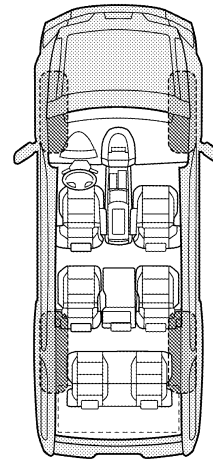
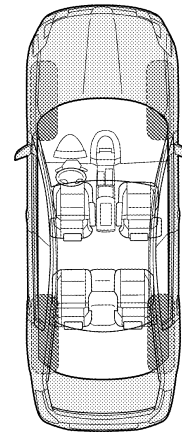
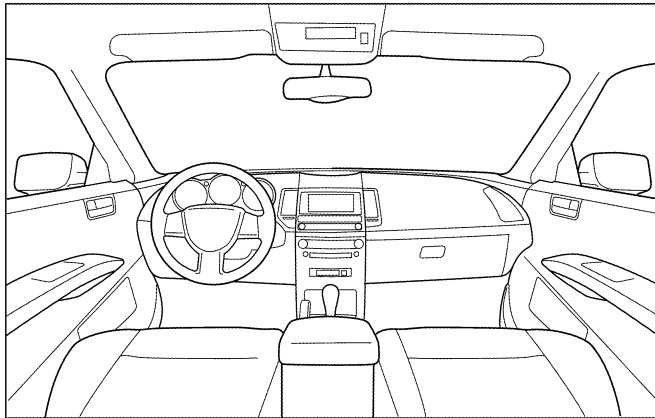

Continue to page 2 of the worksheet and briefly describe the location of the noise or rattle. In addition, please indicate the conditions which are present when the noise occurs.

A
B
C
D
E
F
G
H
I
J
GW
L
M
N
O
P

SQUEAK AND RATTLE TROUBLE DIAGNOSES

< SYMPTOM DIAGNOSIS >

SQUEAK & RATTLE DIAGNOSTIC WORKSHEET - page 2

Briefly describe the location where the noise occurs:

II. WHEN DOES IT OCCUR? (please check the boxes that apply)

- | | |
|---|--|
| <input type="checkbox"/> Anytime | <input type="checkbox"/> After sitting out in the rain |
| <input type="checkbox"/> 1st time in the morning | <input type="checkbox"/> When it is raining or wet |
| <input type="checkbox"/> Only when it is cold outside | <input type="checkbox"/> Dry or dusty conditions |
| <input type="checkbox"/> Only when it is hot outside | <input type="checkbox"/> Other: |

III. WHEN DRIVING:

- Through driveways
- Over rough roads
- Over speed bumps
- Only about ____ mph
- On acceleration
- Coming to a stop
- On turns: left, right or either (circle)
- With passengers or cargo
- Other: _____
- After driving ____ miles or ____ minutes

IV. WHAT TYPE OF NOISE

- Squeak (like tennis shoes on a clean floor)
- Creak (like walking on an old wooden floor)
- Rattle (like shaking a baby rattle)
- Knock (like a knock at the door)
- Tick (like a clock second hand)
- Thump (heavy muffled knock noise)
- Buzz (like a bumble bee)

TO BE COMPLETED BY DEALERSHIP PERSONNEL

Test Drive Notes:

	YES	NO	Initials of person performing
Vehicle test driven with customer	<input type="checkbox"/>	<input type="checkbox"/>	_____
- Noise verified on test drive	<input type="checkbox"/>	<input type="checkbox"/>	_____
- Noise source located and repaired	<input type="checkbox"/>	<input type="checkbox"/>	_____
- Follow up test drive performed to confirm repair	<input type="checkbox"/>	<input type="checkbox"/>	_____

VIN: _____ Customer Name _____
W.O.# _____ Date: _____

This form must be attached to Work Order

LAI0071E

WINDSHIELD GLASS

< REMOVAL AND INSTALLATION >

REMOVAL AND INSTALLATION

WINDSHIELD GLASS

Exploded View

INFOID:000000011932585

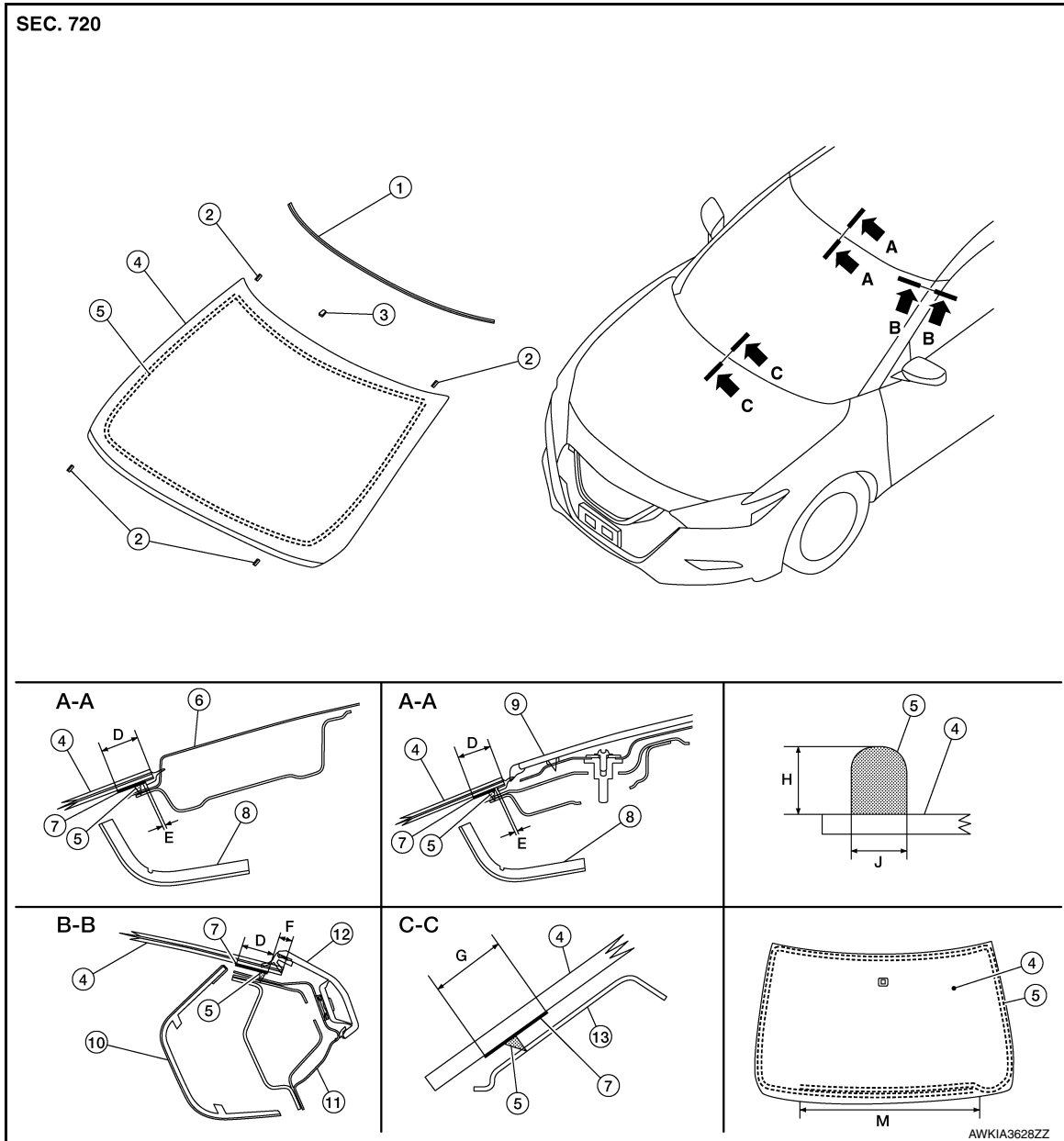

- | | | |
|--|-------------------------------|---|
| 1. Windshield glass molding | 2. Spacer | 3. Mirror base |
| 4. Windshield glass | 5. Adhesive | 6. Metal roof |
| 7. Glass primer | 8. Headlining | 9. Double panel sunroof |
| 10. Front pillar finisher | 11. Body side outer | 12. Front pillar molding |
| 13. Cowl top | D. 16 mm (0.63 in) | E. 1 mm (0.04 in) |
| F. 7.8 mm (0.31 in) | G. 38 mm (1.50 in) | H. 12 + 2, - 0 mm (0.47 + 0.08, - 0 in) |
| J. 7 + 2, - 0 mm (0.28 + 0.08, - 0 in) | M. 1000 mm (39.37 in) overlap | |

Removal and Installation

INFOID:000000011932586

REMOVAL

A
B
C
D
E
F
G
H
I
J
K
L
M
N
O
P

GW

WINDSHIELD GLASS

< REMOVAL AND INSTALLATION >

1. Remove cowl top cover. Refer to [EXT-25, "Removal and Installation"](#).
2. Remove front pillar molding (RH/LH). Refer to [EXT-34, "Removal and Installation"](#).
3. Remove roof side molding. Refer to [EXT-36, "Removal and Installation"](#).
4. Remove inside mirror. Refer to [MIR-20, "Removal and Installation"](#).
5. Remove rain sensor (if equipped). Refer to [WW-57, "Removal and Installation"](#).
6. Partially lower headlining (front edge). Refer to [INT-47, "Exploded View"](#).
7. Remove windshield glass using piano wire or power cutting tool (A) and an inflatable pump bag (B).

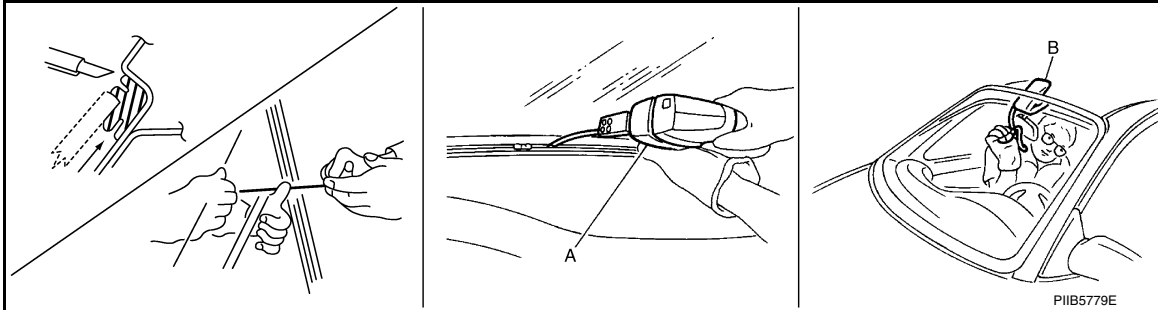

- Apply protective tape around the windshield glass to protect the painted surface from damage.
- If the windshield glass is to be reused, mark the body and the glass with matching marks.

WARNING:

When cutting the glass from the vehicle, always wear safety glasses and heavy gloves to help prevent glass splinters from entering your eyes or cutting your hands.

CAUTION:

- Be careful not to scratch the glass when removing.
- Do not set or stand glass on its edge. Small chips may develop into cracks.
- Apply a protective tape around the windshield glass to protect the painted surface from damage.

INSTALLATION

Installation is in the reverse order of removal.

- Use a genuine NISSAN Urethane Adhesive Kit (if available) or equivalent and follow the instructions furnished with it.
- Adhesive shall be continuously applied to assure watertightness. Glass installation must be finished within five minutes after applying the adhesive.
- While the urethane adhesive is curing, open a door window. This will prevent the glass from being forced out by passenger compartment air pressure when a door is closed.
- The molding must be installed securely so that it is in position and leaves no gap.
- Inform the customer that the vehicle should remain stationary until the urethane adhesive has completely cured (preferably 24 hours). Curing time varies with temperature and humidity.

WARNING:

- Keep heat and open flames away as primers and adhesive are flammable.
- The materials contained in the kit are harmful if swallowed, and may irritate skin and eyes. Avoid contact with the skin and eyes.
- Use in an open, well ventilated location. Avoid breathing the vapors. They can be harmful if inhaled. If affected by vapor inhalation, immediately move to an area with fresh air.
- Driving the vehicle before the urethane adhesive has completely cured may affect the performance of the windshield in case of an accident.

CAUTION:

- Do not use an adhesive which is past its usable term. Shelf life of this product is limited to six months after the date of manufacture. Carefully adhere to the expiration or manufacture date printed on the box.
- Keep primers and adhesive in a cool, dry place. Ideally, they should be stored in a refrigerator.
- Do not leave primers or adhesive cartridge unattended with their caps open or off.
- The vehicle should not be driven for at least 24 hours or until the urethane adhesive has completely cured. Curing time varies depending on temperature and humidity. The curing time will increase under lower temperatures and lower humidity.

REPAIRING WATER LEAKS FOR WINDSHIELD

- Leaks can be repaired without removing and reinstalling glass.
- If water is leaking between the urethane adhesive material and body or glass, determine the extent of leak.
- This can be done by applying water to the windshield area while pushing glass outward.

WINDSHIELD GLASS

< REMOVAL AND INSTALLATION >

- To stop the leak, apply primer (if necessary) and then urethane adhesive to the leak point.

A

B

C

D

E

F

G

H

I

J

GW

L

M

N

O

P

FRONT DOOR GLASS

< REMOVAL AND INSTALLATION >

FRONT DOOR GLASS

Exploded View

INFOID:000000011932591

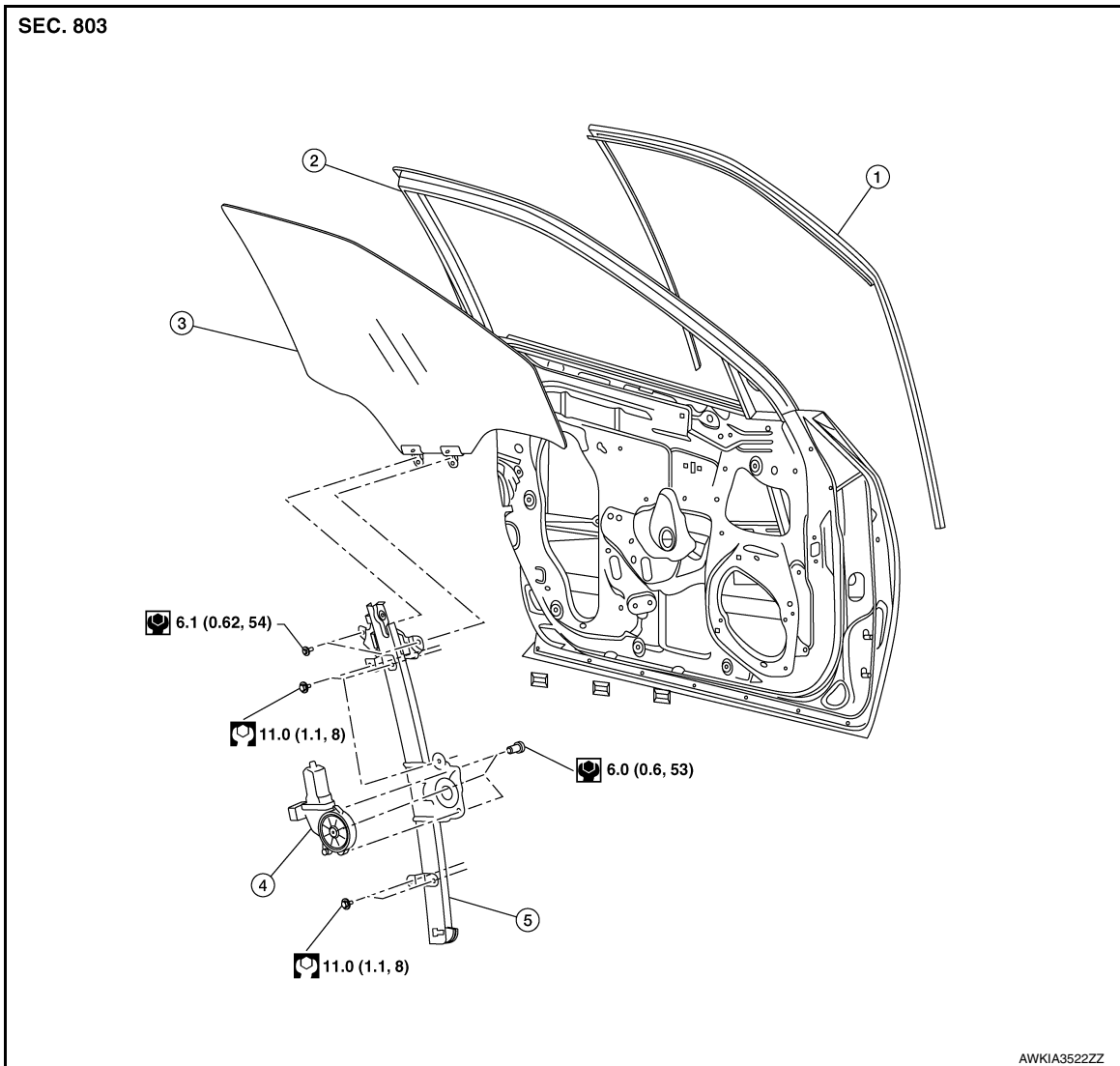

- | | | |
|-----------------------------|-------------------------|---------------|
| 1. Door glass rubber run | 2. Door | 3. Door glass |
| 4. Front power window motor | 5. Door glass regulator | |

Removal and Installation

INFOID:000000011932592

REMOVAL

1. Remove front door finisher. Refer to [INT-27. "Removal and Installation"](#).
2. Remove bolt hole covers (A).

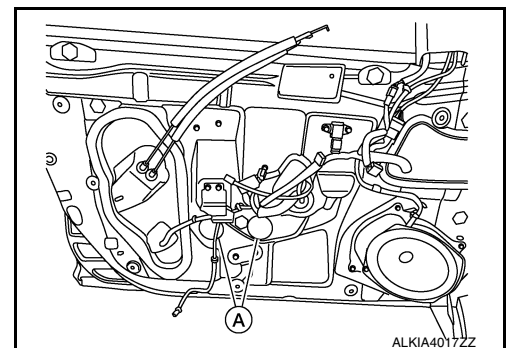

FRONT DOOR GLASS

< REMOVAL AND INSTALLATION >

3. Temporarily reconnect main power window and door lock/unlock switch (LH door) or power window and door lock/unlock switch RH (RH door).
4. Operate main power window and door lock/unlock switch (LH door) or power window and door lock/unlock switch RH (RH door) to raise/lower the door glass until the door regulator to glass bolts can be seen.
5. Remove door glass regulator to glass bolts (A).

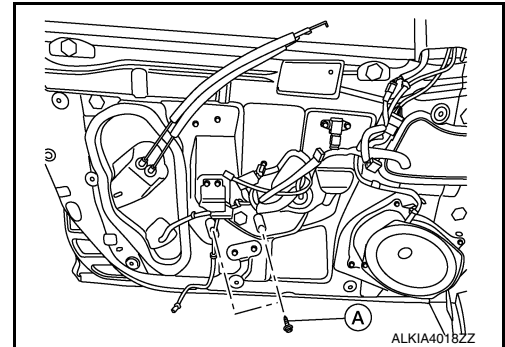

6. While holding door glass, raise it at the rear end and pull door glass out of door glass rubber run toward the outside of the door.

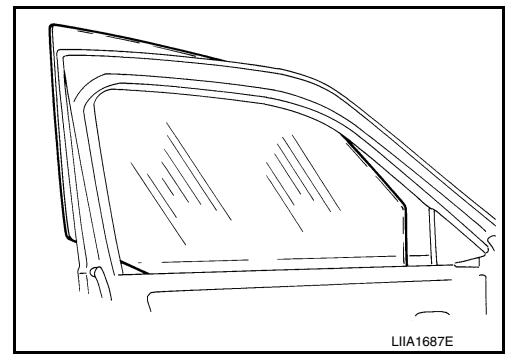

INSTALLATION

Installation is in the reverse order of removal.

CAUTION:

After door glass installation is complete:

- Perform the System Initialization. Refer to [PWC-30, "Description"](#).
- Check the Anti-Pinch function. Refer to [PWC-31, "Description"](#).

FITTING INSPECTION

- Check that the glass is securely fit into the door glass rubber run groove.
- Lower the door glass slightly [approximately 10 to 20 mm (0.4 to 0.8 in)] and check that the clearance to the door glass rubber run is parallel. If the clearance between the glass and sash is not parallel, loosen the regulator bolts and glass to regulator bolts to correct the glass position.

A
B
C
D
E
F
G
H
I
J
L
M
N
O
P

GW

FRONT REGULATOR

< REMOVAL AND INSTALLATION >

FRONT REGULATOR

Exploded View

INFOID:000000011932594

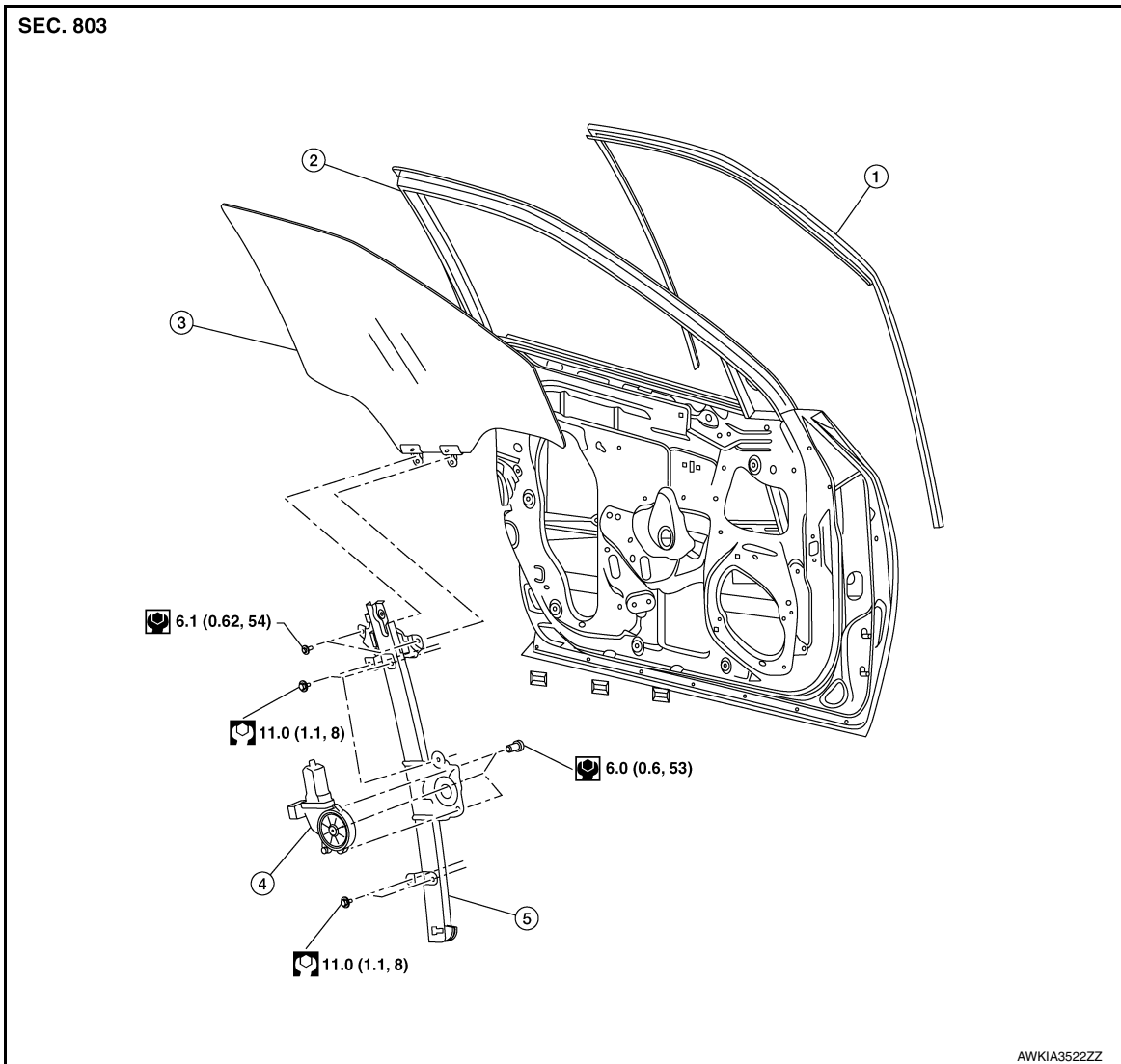

- | | | |
|-----------------------------|-------------------------|---------------|
| 1. Door glass rubber run | 2. Door | 3. Door glass |
| 4. Front power window motor | 5. Door glass regulator | |

Removal and Installation

INFOID:000000011932595

REMOVAL

1. Remove front door finisher. Refer to [INT-27. "Removal and Installation"](#).
2. Remove bolt hole covers (A).

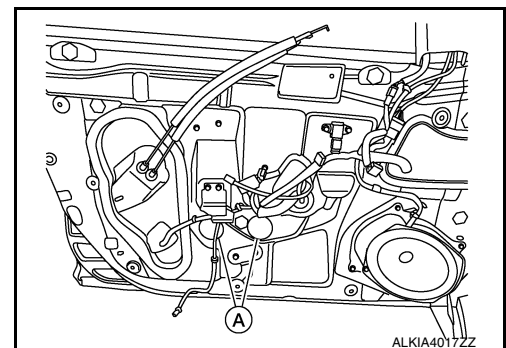

FRONT REGULATOR

< REMOVAL AND INSTALLATION >

3. Temporarily reconnect main power window and door lock/unlock switch (LH door) or power window and door lock/unlock switch RH (RH door).
4. Operate main power window and door lock/unlock switch (LH door) or power window and door lock/unlock switch RH (RH door) to raise/lower the door glass until the door glass regulator to glass bolts can be seen.
5. Remove door glass regulator to glass bolts (A).

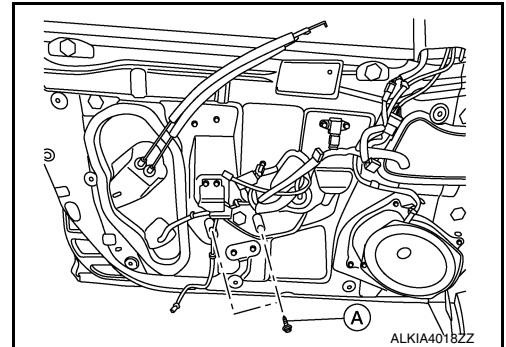

6. Raise door glass and hold in place using a suitable tool (A).

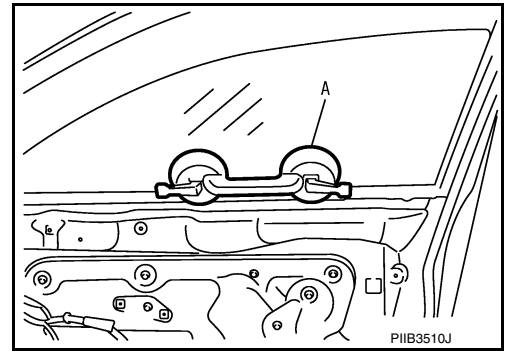

7. Remove door vapor barrier (1).

CAUTION:

Use care not to damage or tear vapor barrier during removal.

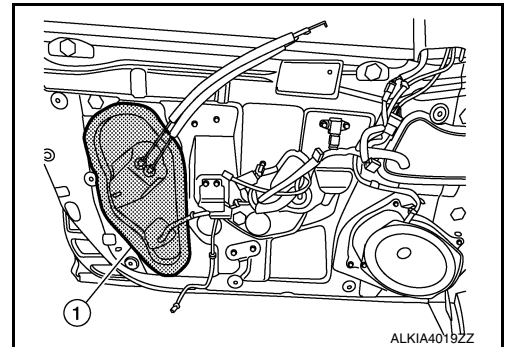

8. Disconnect harness connector from door glass regulator motor.
9. Remove bolts (B) and nut (A) then door glass regulator from door.

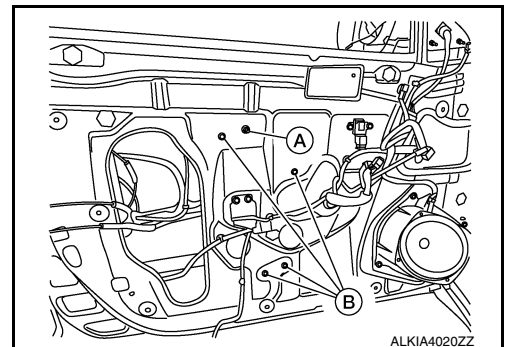

INSPECTION AFTER REMOVAL

Check the door glass regulator for the following items:

- Wire wear
- Regulator deformation

A
B
C
D
E
F
G
H
I
J
GW
L
M
N
O
P

FRONT REGULATOR

< REMOVAL AND INSTALLATION >

- Grease condition for each sliding part
- If a malfunction is detected, replace or grease it using multi-purpose grease as shown (←).

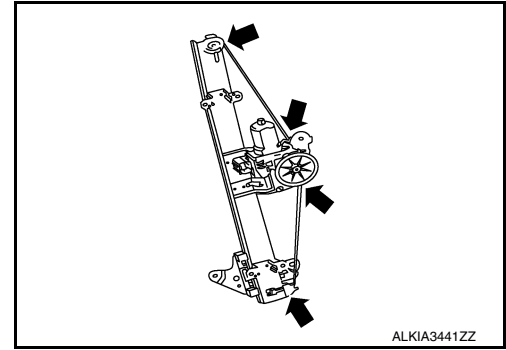

INSTALLATION

Installation is in the reverse order of removal.

FITTING INSPECTION

CAUTION:

After door glass installation is complete:

- **Perform the System Initialization. Refer to [PWC-30, "Description"](#).**
- **Check the Anti-Pinch function. Refer to [PWC-31, "Description"](#).**
- Check that the door glass is securely fit into the door glass rubber run groove.
- Lower the door glass slightly [approximately 10 to 20 mm (0.4 to 0.8 in)] and check that the clearance to the door glass rubber run is parallel. If the clearance between the glass and door glass rubber run is not parallel, loosen the regulator bolts and glass to regulator bolts to correct the glass position.

FRONT POWER WINDOW MOTOR

< REMOVAL AND INSTALLATION >

FRONT POWER WINDOW MOTOR

Removal and Installation

INFOID:000000012246206

REMOVAL

1. Remove front regulator. Refer to [GW-16. "Removal and Installation"](#).
2. Remove screws (A) and front power window motor (1) from door glass regulator (2).

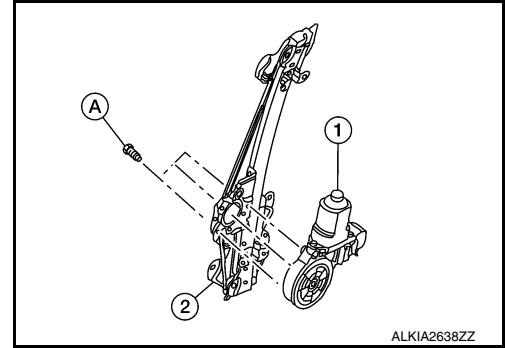

INSTALLATION

Installation is in the reverse order of removal.

A
B
C
D
E
F
G
H
I
J
L
M
N
O
P

GW

REAR DOOR GLASS

< REMOVAL AND INSTALLATION >

REAR DOOR GLASS

Exploded View

INFOID:000000011932597

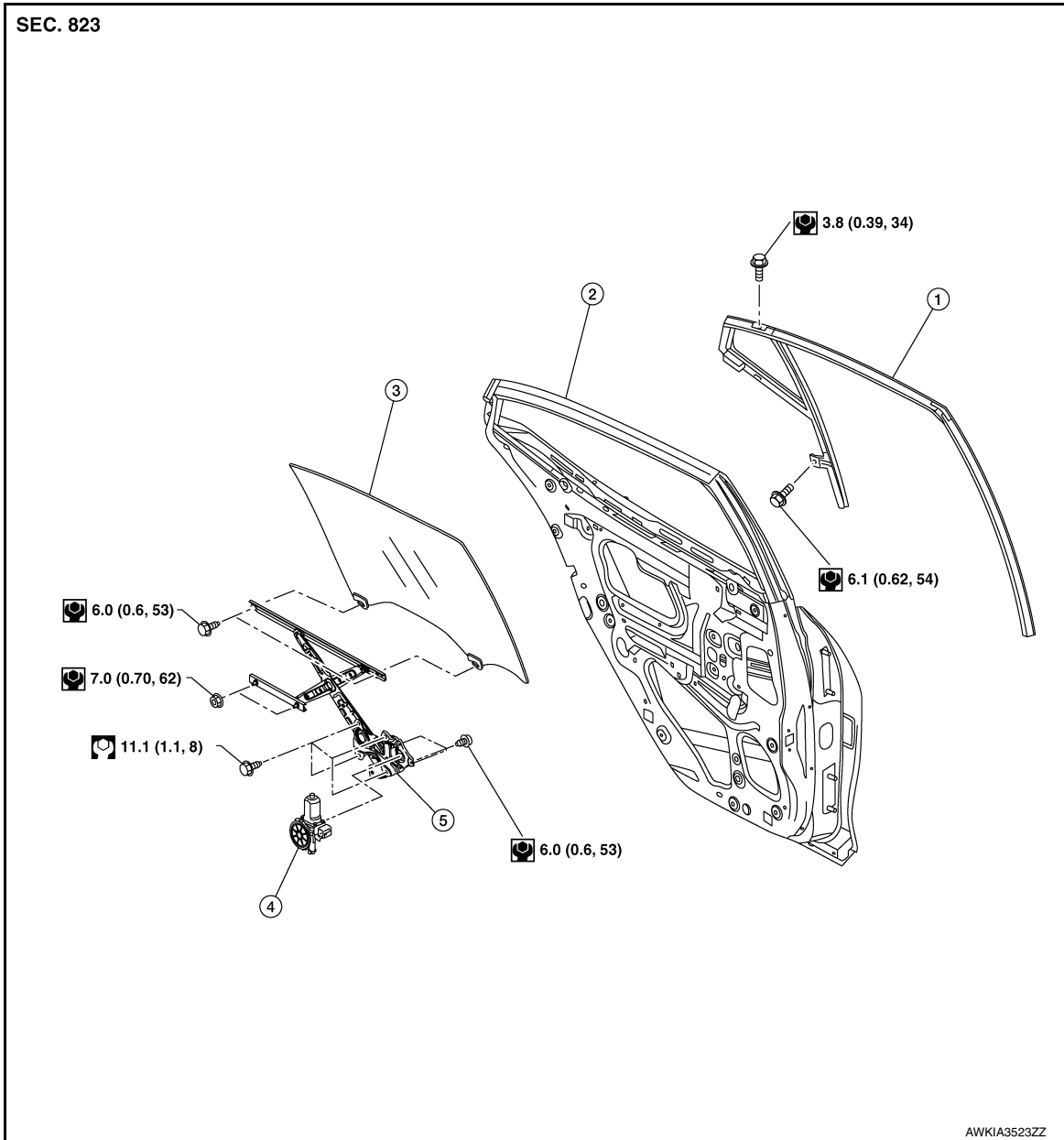

- | | | |
|--|-------------------------|---------------|
| 1. Door glass rubber run and partition glass | 2. Door | 3. Door glass |
| 4. Rear power window motor | 5. Door glass regulator | |

Removal and Installation

INFOID:000000011932598

REMOVAL

1. Remove the rear door finisher. Refer to [INT-29. "Removal and Installation"](#).

REAR DOOR GLASS

< REMOVAL AND INSTALLATION >

2. Remove bolts (A) and bracket.

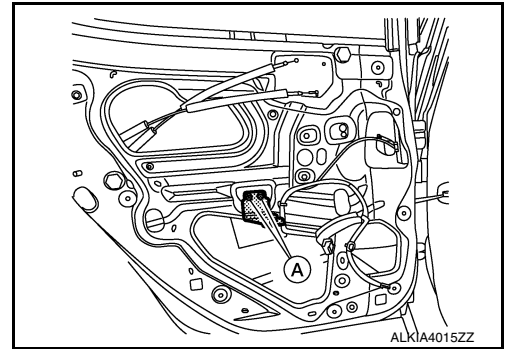

3. Remove vapor barrier.

CAUTION:

Use care not to damage or tear vapor barrier during removal.

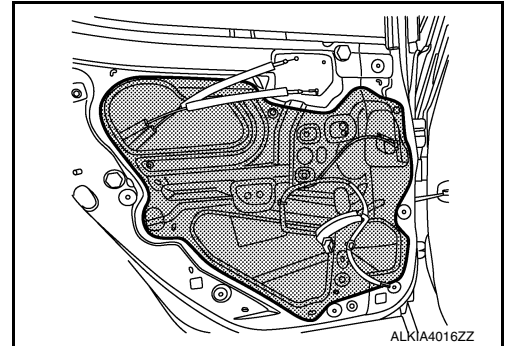

4. Temporarily reconnect the power window switch and raise/lower the door glass until the glass bolts (A) can be seen.
5. Remove door glass bolts and place door glass on the inner bottom of door.

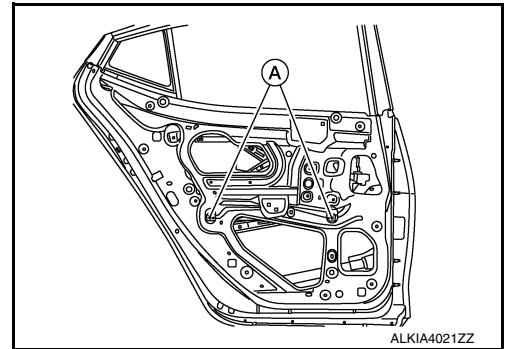

6. Remove screw (A), bolt (B).

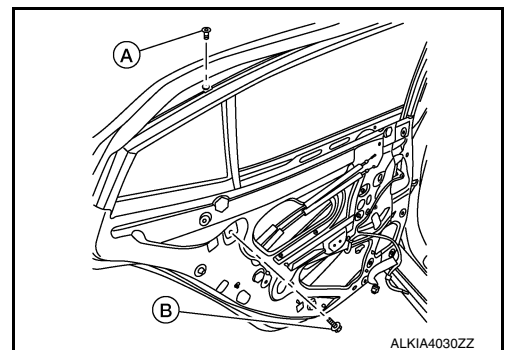

7. Remove the door glass rubber run and partition glass.
8. Remove door glass from the bottom of the door.

INSTALLATION

Installation is in the reverse order of removal.

FITTING INSPECTION

- Check that the glass is securely fit into the door glass rubber run groove.
- Lower the door glass slightly [approximately 10 to 20 mm (0.4 to 0.8 in)] and check that the clearance to the door glass rubber run is parallel. If the clearance between the door glass and door glass rubber run is not parallel, loosen the regulator nuts and bolts and glass to regulator bolts to correct the glass position.

A
B
C
D
E
F
G
H
I
J
GW
L
M
N
O
P

REAR REGULATOR

< REMOVAL AND INSTALLATION >

REAR REGULATOR

Exploded View

INFOID:000000012287543

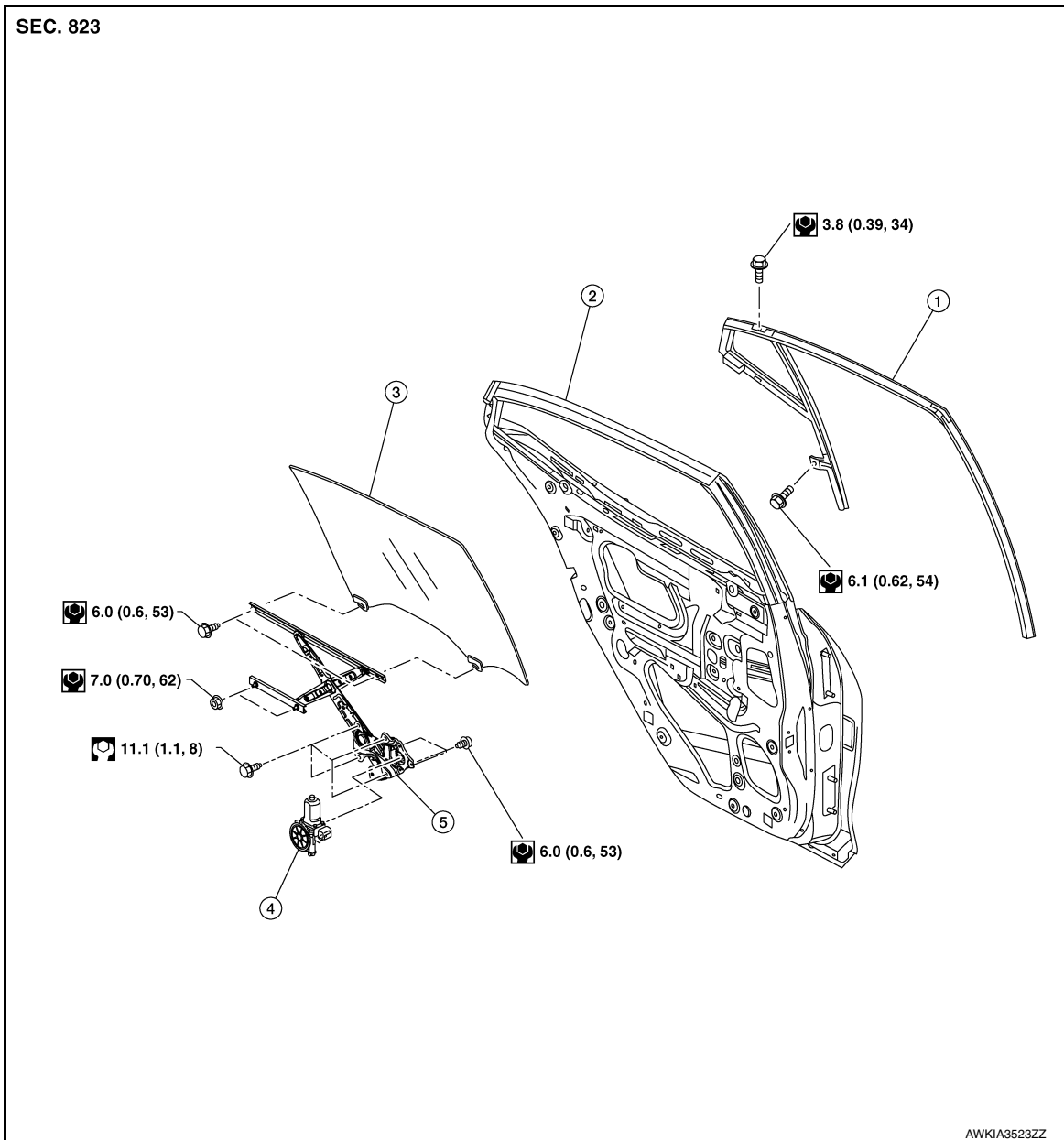

- | | | |
|--|-------------------------|---------------|
| 1. Door glass rubber run and partition glass | 2. Door | 3. Door glass |
| 4. Rear power window motor | 5. Door glass regulator | |

Removal and Installation

INFOID:000000011932600

REMOVAL

1. Remove rear door finisher. Refer to [INT-29. "Removal and Installation"](#).

REAR REGULATOR

< REMOVAL AND INSTALLATION >

2. Remove bolts (A) and bracket.

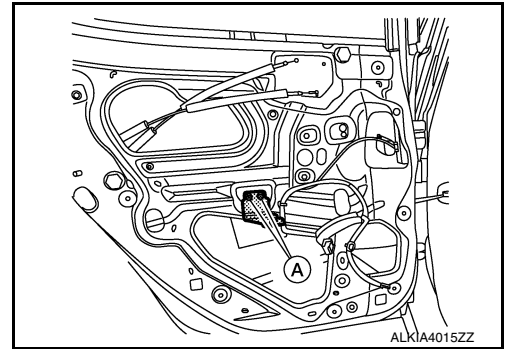

3. Remove door vapor barrier.

CAUTION:

Use care not to damage or tear vapor barrier during removal.

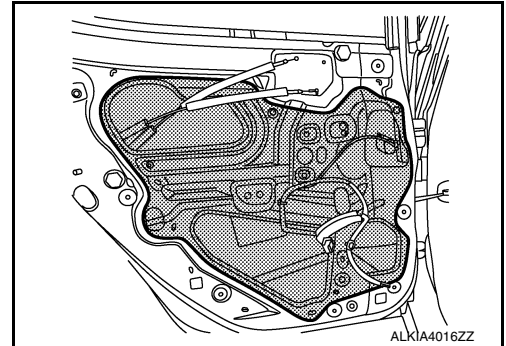

4. Temporarily reconnect the power window switch and raise/lower the door glass until the glass bolts (A) can be seen and remove.

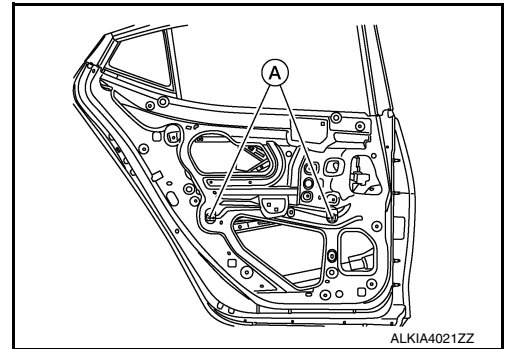

5. Raise door glass and hold in place with suitable tool (A).

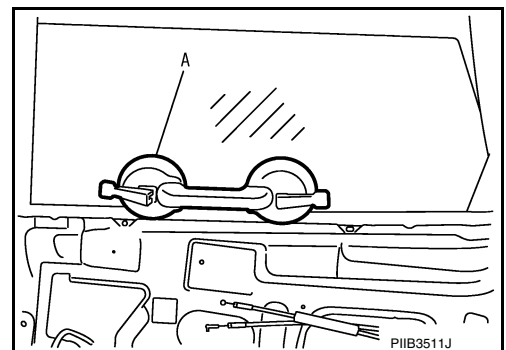

6. Disconnect harness connector from door glass regulator.

A
B
C
D
E
F
G
H
I
J
GW
L
M
N
O
P

REAR REGULATOR

< REMOVAL AND INSTALLATION >

7. Remove door glass regulator nuts (A) and bolts (B).
8. Loosen bolt (C) and remove door glass regulator.

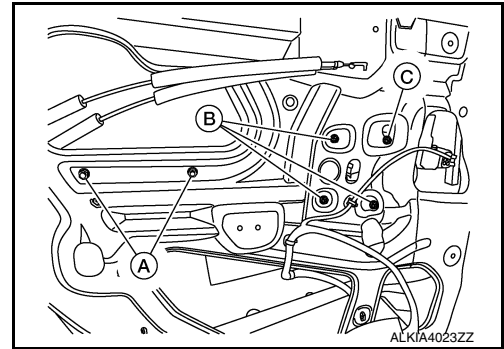

9. Remove regulator from door.

INSPECTION AFTER REMOVAL

Check the door glass regulator for the following items:

- Gear wear
- Door glass regulator deformation
- Spring damage
- Grease condition for each sliding part

If a malfunction is detected, replace or grease it using multi-purpose grease as shown.

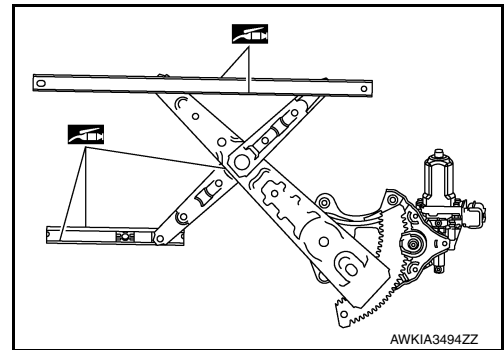

INSTALLATION

Installation is in the reverse order of removal.

FITTING INSPECTION

- Check that the glass is securely fit into the door glass rubber run groove.
- Lower the door glass slightly [approximately 10 to 20 mm (0.4 to 0.8 in)] and check that the clearance to the door glass rubber run is parallel. If the clearance between the glass and door glass rubber run is not parallel, loosen the regulator nuts and bolts and glass to regulator bolts to correct the glass position.

REAR POWER WINDOW MOTOR

< REMOVAL AND INSTALLATION >

REAR POWER WINDOW MOTOR

Removal and Installation

INFOID:000000012246207

REMOVAL

1. Remove rear regulator. Refer to [GW-22. "Removal and Installation"](#).
2. Remove screws (A) and rear door power window motor (1) from door glass regulator (2).

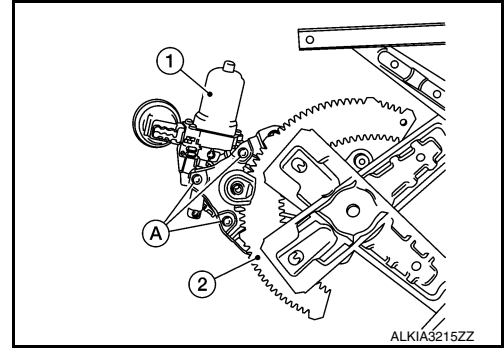

INSTALLATION

Installation is in the reverse order of removal.

A
B
C
D
E
F
G
H
I
J
L
M
N
O
P

GW

REAR WINDOW GLASS

< REMOVAL AND INSTALLATION >

REAR WINDOW GLASS

Exploded View

INFOID:000000011932588

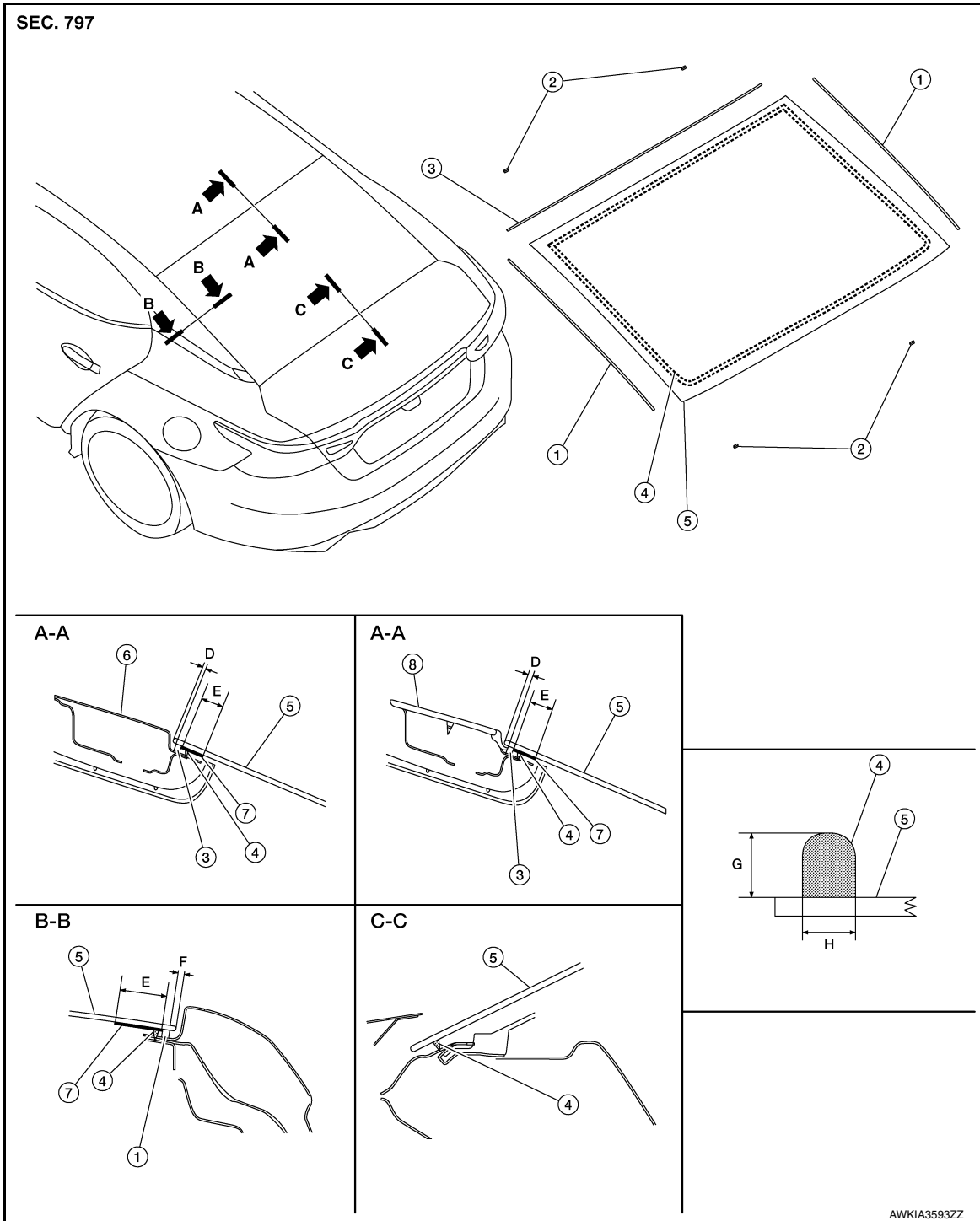

- | | | |
|-------------------------------------|-------------------------|-------------------------------------|
| 1. Dam sealant rubber (side) | 2. Spacer | 3. Dam sealant rubber (upper) |
| 4. Adhesive | 5. Rear window glass | 6. Metal roof |
| 7. Glass primer | 8. Double panel sunroof | D. 2.7 mm (0.11 in) |
| E. 16 +2, -0 mm (0.63 +0.08, -0 in) | F. 4 mm (0.16 in) | G. 12 +2, -0 mm (0.47 +0.08, -0 in) |
| H. 7 +2, -0 mm (0.28 +0.08, -0 in) | | |

REAR WINDOW GLASS

< REMOVAL AND INSTALLATION >

Removal and Installation

INFOID:000000011932589

REMOVAL

1. Partially lower headliner (rear edge). Refer to [INT-47, "Exploded View"](#).
2. Remove roof side moldings. Refer to [EXT-36, "Exploded View"](#).
3. Disconnect harness connectors from rear window defogger and antenna.
4. Remove glass using piano wire or power cutting tool (A) and an inflatable pump bag (B).

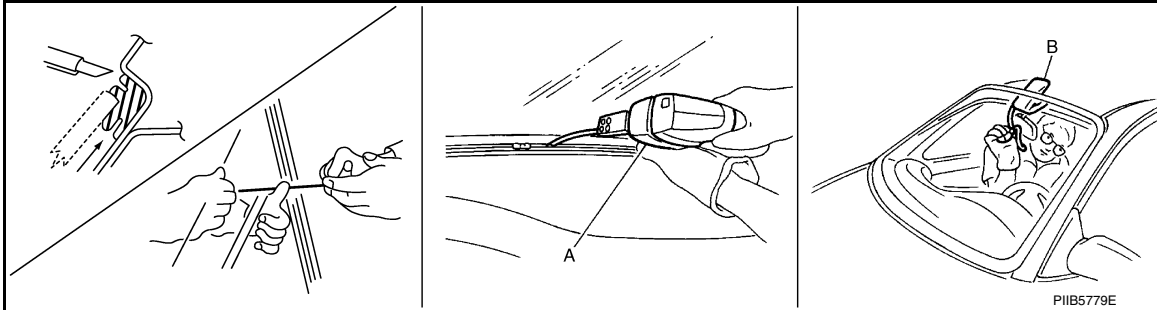

- Apply protective tape around the rear window glass to protect the painted surface from damage.
- If the rear window glass is to be reused, mark the body and the glass with mating marks.

WARNING:

When cutting the glass from the vehicle, always wear safety glasses and heavy gloves to help prevent glass splinters from entering your eyes or cutting your hands.

CAUTION:

- **When the rear window glass is to be reused, do not use a cutting knife or power cutting tool.**
- **Be careful not to scratch the glass when removing.**
- **Do not set or stand the glass on its edge. Small chips may develop into cracks.**

INSTALLATION

Installation is in the reverse order of removal.

- Use a genuine NISSAN Urethane Adhesive Kit (if available) or equivalent and follow the instructions furnished with it.
- Adhesive shall be continuously applied to assure watertightness. Glass installation should be finished within five minutes after applying the adhesive.
- While the urethane adhesive is curing, open a door window. This will prevent the glass from being forced out by passenger compartment air pressure when a door is closed.
- The molding must be installed securely so that it is in position and leaves no gap.
- Inform the customer that the vehicle should remain stationary until the urethane adhesive has completely cured (preferably 24 hours). Curing time varies with temperature and humidity.

WARNING:

- **Keep heat and open flames away as primers and adhesive are flammable.**
- **The materials contained in the kit are harmful if swallowed, and may irritate skin and eyes. Avoid contact with the skin and eyes.**
- **Use in an open, well ventilated location. Avoid breathing the vapors. They can be harmful if inhaled. If affected by vapor inhalation, immediately move to an area with fresh air.**
- **Driving the vehicle before the urethane adhesive has completely cured may affect the performance of the windshield in case of an accident.**

CAUTION:

- **Do not use an adhesive which is past its usable term. Shelf life of this product is limited to six months after the date of manufacture. Carefully adhere to the expiration or manufacture date printed on the box.**
- **Keep primers and adhesive in a cool, dry place. Ideally, they should be stored in a refrigerator.**
- **Do not leave primers or adhesive cartridge unattended with their caps open or off.**
- **The vehicle should not be driven for at least 24 hours or until the urethane adhesive has completely cured. Curing time varies depending on temperature and humidity. The curing time will increase under lower temperatures and lower humidity.**

REPAIRING WATER LEAKS FOR BACK GLASS

- Leaks can be repaired without removing and reinstalling glass.

REAR WINDOW GLASS

< REMOVAL AND INSTALLATION >

- If water is leaking between the urethane adhesive material and body or glass, determine the extent of leakage.
- This can be done by applying water to the glass area while pushing glass outward.
- To stop the leak, apply primer (if necessary) and then urethane adhesive to the leak point.